

MODEL WCU-CHB (Screw Compressor)

PACKAGED WATER COOLED CHILLER

43.1 - 180 TR

151.5 – 633 kW



UNI-Aire[®]

Air Conditioning Experts

Touch screen display

- LCD Display touch terminals
- Designed to make the interaction between man and machine simple and intuitive, making navigation easier between the various screens.

1. Able to view the operating values from the circuit shown on the screen.
 - - Set Water Temperature
 - - Set Delay Time
 - - Set Protection
 - - Calibration
 - - Supervisor
2. Alarm
 - - Active Alarm Compressor
 - - Active Alarm Etc. (Phase Protection, Flow Switch, Water Freeze, Chiller Water Pump, AUX pump)
3. Setting
4. Display locking by setting a password

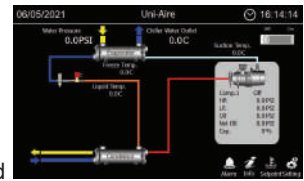

Programmable logic control : PLC



- Able to edit operation programs through “Host” and “Device” USB ports with standard USB flash drives
- Direct connection PC without needing a serial converter.
- (Option) Connection to the controller is available over an RS485 or Ethernet network using the ModBus or BACnet protocol.

Semi-Hermetic screw compressor

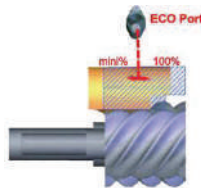

Refrigerant R134a

- Compressors maintain the liquid flow rate to meet the working load at 50% -100% (full load).
- Effective under partial load and full load
- Designed for commercial & industrial applications.

- R134a is a refrigerant of the HFC group with no harmful effects on the ozone layer.
- No toxic
- Not combustible
- Does not corrode equipment

Evaporator (Shell and tube heat exchanger)

- High efficiency performance , low water pressure drop
- Aluminium star rods fitted in copper tubing , create turbulence refrigerant flow and cause higher heat transfer efficiency.
- Removable head and proper selection of head pass avoids excessive refrigerant pressure drops.
- High column strength tube design reduces the hazard of freeze-up.
- Thick insulation to prevent condensation.



Condenser (Shell and tube heat exchanger)



- Cleanable water cooled condensers are heavy duty high efficiency condensers
- Specially designed to simplify the mechanical cleaning necessary in area where poor water conditions exist.
- Working pressure
 - Shell side, 325 PSI
 - Tube side, 125 PSI
 - Test pressure 1.25 times the design working pressure
- Optional : Sea water application Copper-Nickels (90-10 / CU-NI), Tubes surrounded by steel outer tube (Shell).

Refrigeration part



Hi-Low pressure gauge



Solenoid valve

Use electric power to control valve opening and closing.



Sight glass

Characterize the state and humidity of the refrigerant.



Filter drier

Filters out dirt and absorbs moisture. If the machine does not work properly or has acid build-up, the filter drier will also absorb the acid by the filter drier's inner filling.



Chilled water flow switch

Check water flow for protect system



Thermostatic expansion valve

Controls the amount of refrigerant entering the evaporator. By installing this thermostatic expansion valve on the inlet pipe before the refrigerant enters the evaporator.

Electical parts

- Magnatic & Overload contractor for fan motor and compressor
- Unit main breaker
- Digital hour meter
- Phase protection
- Pressure transducer
- Freezestat
- Crankcase heaters

Dimensional drawings

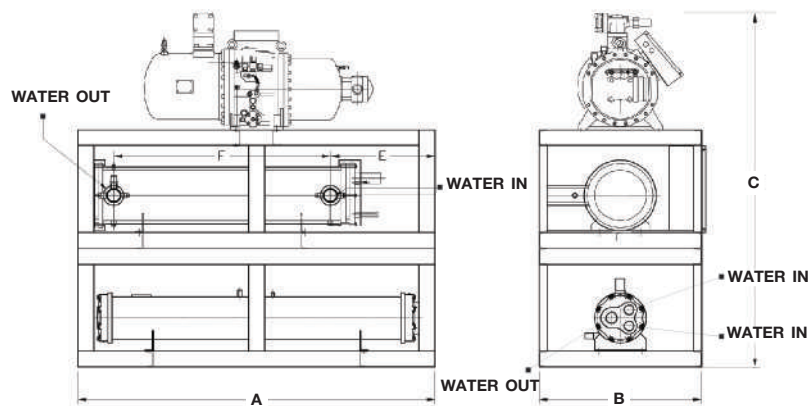

WCU-CHB 050-080

MODEL	DIMENSION MODEL : WCU-CHB		
	A (mm.)	B (mm.)	C (mm.)
050	2,200	1,000	2,236
060	2,500		
070	3,000	1,140	2,523
080			

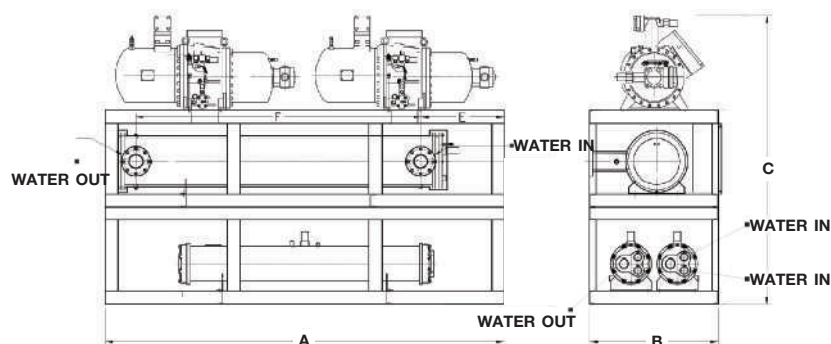

WCU-CHB 100-240

MODEL	DIMENSION MODEL : WCU-CHB		
	A (mm.)	B (mm.)	C (mm.)
100	3,100	1,000	2,236
120	3,700	1,140	2,436
150	3,700	1,140	2,473
180	3,700	1,140	2,523
200	4,300	1,140	2,523
240	4,300	1,140	2,676

PHYSICAL DATA

SPECIFICATION MODEL : WCU-CHB (Comp. SCREW)												
MODEL	WCU-CHB	050	060	070	080	100	120	150	180	200	240	
NOMINAL COOLING CAPACITY	(MBH)	517	630	668	808	1,034	1,258	1,456	1,761	2,007	2,160	
POWER CONSUMPTION	kw	36.7	43.1	45.9	53.4	73.4	86.2	99.0	119.4	134.8	145.8	
NOMINAL COP	kw/kw	4.13	4.28	4.27	4.43	4.13	4.28	4.31	4.32	4.36	4.34	
IPLV.IP**	kw/kw	4.83	5.06	4.99	5.19	4.83	5.02	5.04	5.06	5.11	5.09	
COMPRESSOR	TYPE	SCREW										
	HP.	50	60	70	80	50	60	75	90	100	120	
	QTY./UNIT	1					2					
REFRIGERANT	TYPE	R134A										
	CHARGE	Holding										
WATER COOLED CONDENSER	FOULING FACTOR	0.0005 (0.000046) Ft ² .h.F./BTU (m ² .h.F./BTU)										
	WATER FLOW RATE	(GPM)	138	168	178	215	276	335	388	470	535	576
	ENTERING WATER TEMP.	(°F)	90									
	LEAVING WATER TEMP.	(°F)	100									
	WATER PRESSURE DROP	(Ft.WG)	6.78	5.67	5.9	5.74	13.56	11.34	11.8	11.48	20.52	16.37
	NO. OF WATER PASSER		2									
	WATER CONNECTION (IN..OUT)	INCH	2-1/2...3	3...4			2-1/2...3	3...4				
	QTY./UNIT		1					2				
WATER CHILLER	FOULING FACTOR	0.0005 (0.000046) Ft ² .h.F./BTU (m ² .h.F./BTU)										
	NO. OF CIRCUIT		1				2					
	CHILLED WATER FLOW RATE	(GPM)	103	126	134	162	207	252	291	352	401	432
	CHILLED WATER TEMP. IN/OUT	(°F)	55/45									
	CHILLED WATER PRESSURE DROP	(Ft.WG)	3.87	3.13	8.07		13.90	8.63	13.01	14.71	21.47	10.04
	WATER CONNECTION IN/OUT	INCH	3		4			5		6		8
	QTY./UNIT		1									
WEIGHT	(Kgs)	1,622	1,875	1,993	2,130	2,740	3,184	3,601	4,149	4,696	4,908	
kW/Tons		0.85	0.82		0.79	0.85		0.82	0.81			

Note

MBH = 1000 BTUH

FOR SI. UNIT, COOLING CAPACITY (KW) = (MBH x 1000) / 3412

* Nominal Cooling Capacity Based on 38°F Suction Temp. Liquid Subcooled 15°F

** IPLV calculations according to standard performances (in accordance with AHRI 550-590)

ELECTRICAL DATA

MODEL WCU-CHB		050	060	070	080	100	120	150	180	200	240
COMPRESSOR (EACH)	V/PH/Hz	380/3/50									
	POWER INPUT(kw)	36.7	43.1	45.9	53.4	36.7	43.1	49.5	59.7	67.4	72.9
	RLA. (Amp.)	68.1	78.6	82.7	95.9	68.1	78.6	90.1	104.8	119.3	131.6
	LRA. (Amp.)	230	260		345	230	260	345	292	407	443

Note

RLA = Rated Load Amp.

LRA = Locked Rotor Amp.

**Eurovent certified for model DAHH only.



UNIAIRE CORPORATION CO., LTD.

69 Moo 3 Kingkeaw Rd., Rachatewa District, Bangplee, Samutprakarn 10540 Thailand

Email.local@uni-aire.com | Email.export@uni-aire.com

Tel.+662-312-4500, www.uni-aire.com

@uni-aire Uni-Aire Whatsapp.+666-2312-3069

