

# MODEL AHE-H / AKQ

**LOW STATIC ( 75 Pa External Static )**

**FOR DIRECT EXPANSION SYSTEM**

**DUCTED TYPE**

**CAPACITY FROM**

**30,000 TO 60,000 BTUH**

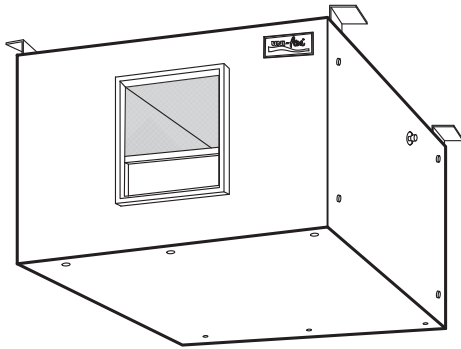

**AHEH (Horizontal)**

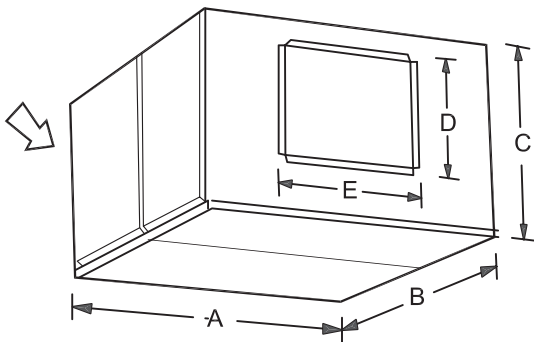

**MODEL : AHEH**

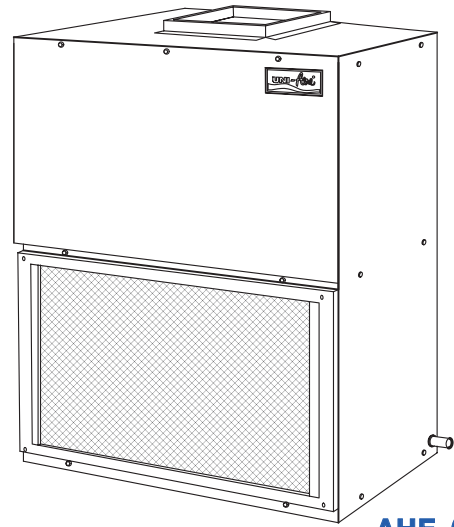

**AHE (Vertical)**

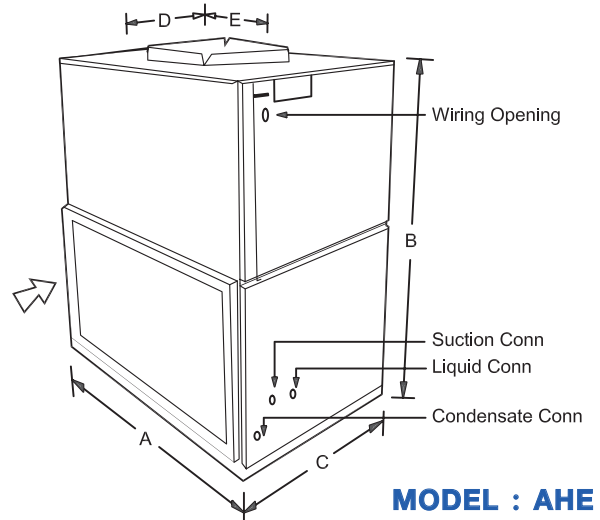

**MODEL : AHE**

MODEL	A	B	C	D	E	Kgs.
AHE-30F	740	917	478	277	260	52
AHE-36F	740	917	478	277	260	54
AHE-40F	924	917	478	277	316	75
AHE-50F	924	917	478	277	316	77
AHE-60F	924	917	478	277	316	78
AHEH-30F	740	938	478	277	260	52
AHEH-36F	740	938	478	277	260	54
AHEH-40F	924	938	478	277	316	75
AHEH-50F	924	938	478	277	316	77
AHEH-60F	924	938	478	277	316	78

**DIMENSION (mm.)**



**Air Conditioning Experts**

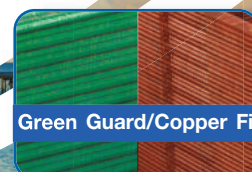

**(Recommend : Don't use long duct)**



Digital wired thermostat (Option)



Wired digital remote controller WIFI (Option)



Wireless digital thermostat (Option)



**Auto Restart**  
Air conditioning system turns on automatically after electricity supply returns from a power failure. the system also memorizes every setting before the outage.

**3 Minute Time Delay**  
Prevent damage to the compressor from voltage sag or power failure.

**2 Speed Motor** 2 speeds adjustable wind blow High-Low For Turbo cool or Quiet cool.

**Turbo Fan** Powerful turbo motor delivers coolness to the room quickly yet quietly.

**PHYSICAL DATA & ELECTRICAL DATA**

SPECIFICATION MODEL : AHE, AHEH / AKQ								
Nominal Cooling Capacity (BTU/Hr)		30,000	36,000	36,000	40,000	50,000	60,000	
SEER (BTU/Hr / Watt)		11.05	11.05	11.05	11.05	11.56	11.05	
COP (Watt / Watt)		3.05	3.05	3.05	3.05	3.19	3.05	
Power Consumption (Watt)		2,820	3,475	3,475	3,869	4,605	5,775	
Rated Operation Current (Amp.)		12.20	15.00	5.90	6.60	8.03	10.25	
Power Supply (Volt/Phase/Hz)		220/1/50		380/3/50				
TIS Standard (มาตรฐาน มอก. 2134-2553)						-	-	
TIS Standard (มาตรฐาน มอก. 1529-2561)								
Fan Coil Unit	Model : AHE, AHEH	AHE, AHEH-30F	AHE, AHEH36F	AHE, AHEH-36F	AHE, AHEH-40F	AHE, AHEH-50F	AHE, AHEH-60F	
	Type	Ducted Type						
Rated Air Flow at High Speed (CFM)		1,000		1,200	1,400	1,600	2,000	
Fan Type		Centrifugal (Direct Drive)						
Evaporator Coil Type		Louver Aluminium Fin with Copper Tube						
Expansion Device Type		Capillary Tube						
Control Type		Option						
Air Filter Type		Aluminium Filter						
Drain Connection (Inch)(OD)		3/4						
AHE : Dimension (W x D x H) (mm.)		740 x 917 x 478		924 x 917 x 478	924 x 917 x 478			
AHE : Weight (kgs.)		52	54	75	77	78		
AHEH : Dimension (W x D x H) (mm.)		740 x 938 x 478		924 x 938 x 478	924 x 938 x 478			
AHEH : Weight (kgs.)		52	54	75	77	78		
Condensing Unit	Model : AKQ	AKQ-301FB	AKQ-361FB	AKQ-363FB	AKQ-403FB	AKQ-503FX	AKQ-603FX	
	Type	Horizontal Air Flow						
Fan Type		Propeller Fan						
Condenser Coil Type		Louver Aluminium Fin with Copper tube						
Compressor Type		Rotary			Scroll			
Refrigerant Type		R-32 (Holding Charge)						
Pipe Connection	Suction Line (Inch)(OD)	3/4						
	Liquid Line (Inch)(OD)	3/8			1/2			
Dimension (W x D x H) (mm.)		835 x 594 x 710			835 x 594 x 812			
Weight (kgs.)		63	70	82	102			

Cooling capacity based on 27 °C DB, 19 °C WB air on evaporator coil and 35 °C DB air on condenser.

Specifications are subjected to change without notice for future improvement.

\*\*Eurovent certified for model DAH1 only.



UNIAIRE CORPORATION CO., LTD.

69 Moo 3 Kingkeaw Rd., Rachatewa District, Bangplee, Samutprakarn 10540 Thailand

Email.local@uni-aire.com | Email.export@uni-aire.com

Tel.+662-312-4500, www.uni-aire.com

@uni-aire Uni-Aire Whatsapp.+666-2312-3069

