

MODEL TACU-CHB

PACKAGED AIR-COOLED CHILLER

8- 30 TR

UNI-Aire[®]

Air Conditioning Experts



SPECIFICATIONS MODEL : TACU-CHB

UNIT CASING

- Constructed of zinc-coated heavy-gauge, galvanized steel
- Powder-coated for protection against rust

COMPRESSOR

- Hermetic scroll compressor
- All compressor are mounted on vibration isolation

REFRIGERANT

- R410a

HEAT EXCHANGER

- Seamless copper tubes, mechanically expanded into aluminium fins with full height collars
- Leak tested at 600 Psig from factory
- High Efficiency AC Axial Fan
- Shell and Tube evaporator

STANDARD ACCESSORIES

REFRIGERATION PARTS

- Service Valves for Liquid line and Suction line
- Thermostatic expansion valves
- Sight Glasses
- Filter Driers

ELECTRICAL PARTS

- Magnetic & Overload contactor for fan motor and compressor
- High-Low pressure switches
- Digital temperature control
- Timer Delay Relay Devices
- Over and Under Voltage Protection

PHYSICAL DATA MODEL : TACU-CHB (008AS-015AS)

Model	TACU-CHB	008AS	009AS	010AS	012AS	015AS
NOMINAL CAPACITY***	MBH.	68.7	78.0	93.4	113.0	139.5
POWER CONSUMPTION	(Watt)	6,635	7,755	8,915	10,930	13,170
POWER SUPPLY	(V/Ph/Hz)	380/3/50				
COMPRESSOR	Type	Hermetic "Scroll"				
	Qty/unit	1				
CONDENSER COIL	Type	Aluminium Louver Fin with Inner Groove Copper Tube				
Face Area	(ft ²)	14.88			20.25	
Rows/FPI		3/14	3/16	4/14	2/16	3/14
Tube Size	(Inch)	7 mm.				
CONDENSER FAN & MOTOR	(Each)	Propeller Fan : Vertical Discharge : Direct Drive				
Quantity		1			2	
Power	(Watt)	485				
RPM		925				
REFRIGERANT	Type	R-410A				
	Charge	Holding Charge : R-410A				
WATER CHILLER		Shell and Tube Heat Exchanger				
Chilled Water Flow Rate	(GPM)	13.7	15.6	18.6	22.6	27.9
Chilled Water Temp. IN/OUT	°F	55/45				
Chilled Water Pressure Drop	(Ft. WG)	2.51	4.08	5.65	8.00	3.69
Water Connection IN/OUT	(Inch)	1-1/4				1-1/2
DIMENSION						
Length	(mm.)	1,500				
Width	(mm.)	810				
Height	(mm.)	1,545				
WEIGHT (Aprox.)	(kgs.)	316	338	361	426	441

***Normal capacity based on 38 °F suction temp. And 95 °F ambient temp (1 MBH=1,000 BTUH)

ELECTRICAL DATA

MODEL	TACU-CHB	008AS	009AS	010AS	012AS	015AS
COMPRESSOR (Each)	Quantity	1				
	Volt/Phase/Hz	380/3/50				
	Power Input (watt)	6,150	7,270	8,430	9,960	12,200
	FLA. (Amp.)	10.98	13.83	16.2	17.99	24.45
	LRA (Amp.)	101	127	153		174
FAN MOTOR (Each)	Quantity	1			2	
	Volt/Phase/Hz	380/3/50				
	Power Input (watt)	485				
	FLA. (Amp.)	1.23				

PHYSICAL DATA MODEL : TACU-CHB (020AS-040AS)

Model	TACU-CHB	020AS	020AS-2C	025AS	025AS-2C	030AS-2C	040AS-2C
NOMINAL CAPACITY***	MBH.	180.0	186.8	224.0	226.0	279.0	360.0
POWER CONSUMPTION	(Watt)	16,220	17,410	22,038	22,658	27,138	34,607
POWER SUPPLY	(V/Ph/Hz)	380/3/50					
COMPRESSOR	Type	Hermetic "Scroll"					
	Qty/unit	1	2	1	2		
CONDENSER COIL	Type	Aluminium Louver Fin with Inner Groove Copper Tube					
Face Area	(ft ²)	23.66		40.51		49.19	
Rows/FPI		4/16		3/14		4/14	3/16
Tube Size	(Inch)	7 mm.					
CONDENSER FAN & MOTOR	(Each)	Propeller Fan : Vertical Discharge : Direct Drive					
Quantity		2					3
Power	(Watt)	485		1,369			
RPM		925		927			
REFRIGERANT	Type	R-410A					
	Charge	Holding Charge : R-410A					
WATER CHILLER		Shell and Tube Heat Exchanger					
Chilled Water Flow Rate	(GPM)	36.0	37.2	44.8	45.3	55.8	72.2
Chilled Water Temp. IN/OUT	°F	55/45					
Chilled Water Pressure Drop	(Ft. WG)	2.23	2.49	4.15	4.22	11.63	7.50
Water Connection IN/OUT	(Inch)	2				2-1/2	3
DIMENSION							
Length	(mm.)	2,100		2,140		2,860	
Width	(mm.)	820		1,260	1,220	1,230	
Height	(mm.)	1,775		1,865			
WEIGHT (Aprox.)	(kgs.)	620	590	725	695	810	980

***Nominal capacity based on 38 °F suction temp. And 95 °F ambient temp (1 MBH=1,000 BTUH)

ELECTRICAL DATA

MODEL	TACU-CHB	020AS	020AS-2C	025AS	025AS-2C	030AS-2C	040AS-2C
COMPRESSOR (Each)	Quantity	1	2	1	2		
	Volt/Phase/Hz	380/3/50					
	Power Input (Watt)	15,250	8,220	19,300	9,960	12,200	15,250
	FLA. (Amp.)	26.81	14.53	34.31	17.99	24.45	26.81
	LRA (Amp.)	219	153	272	153	174	219
FAN MOTOR (Each)	Quantity	2					3
	Volt/Phase/Hz	380/3/50					
	Power Input (Watt)	485		1,369			
	FLA. (Amp.)	1.23		3.36			

DIMENSIONAL DRAWINGS MODEL : TACU-CHB

MODEL : TACU-CHB-008AS, 009AS, 010AS

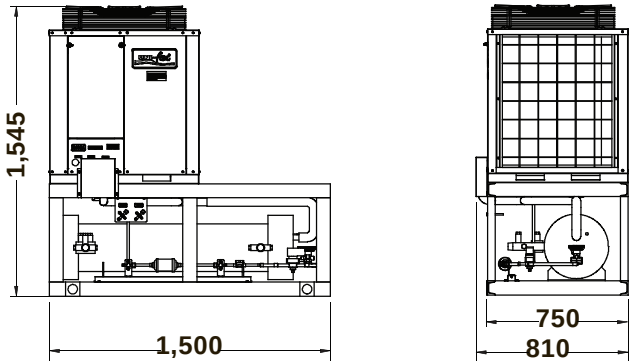

MODEL : TACU-CHB-012AS, 015AS

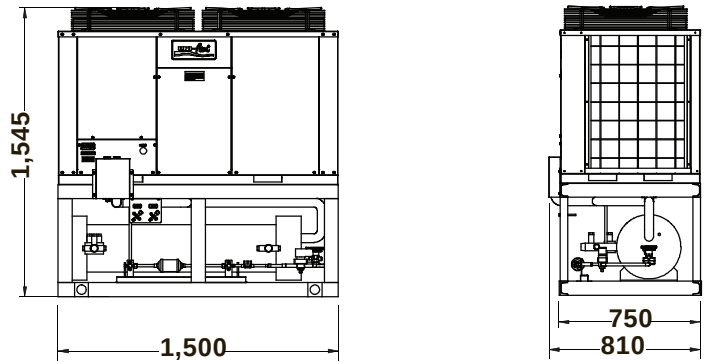

MODEL : TACU-CHB-020AS, 020AS-2C

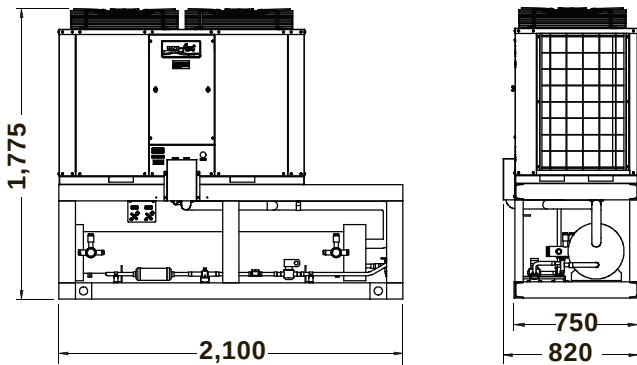

MODEL : TACU-CHB-025AS, 025AS-2C

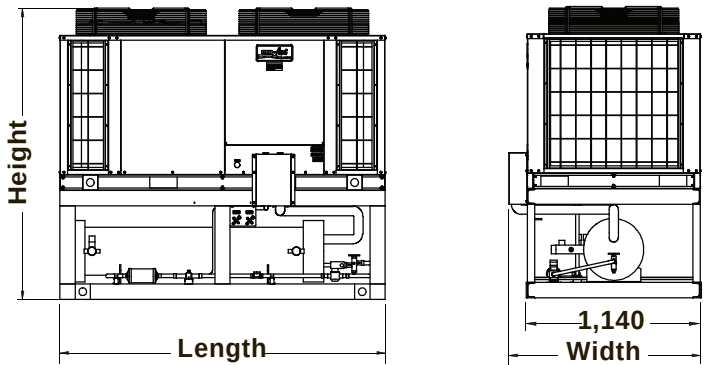

Model	Length	Width	Height
TACU-CHB 025AS	2,140	1,260	1,865
TACU-CHB 025AS-2C		1,220	

MODEL : TACU-CHB-030AS-2C

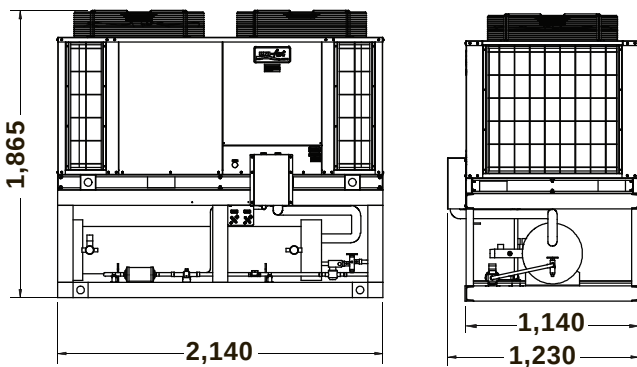

MODEL : TACU-CHB-040AS -2C

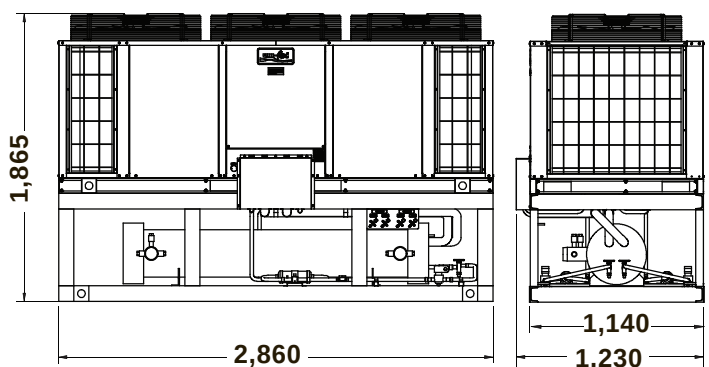

Unit : mm.(Millimeter)

**Eurovent certified for model DAHH only.



UNIAIRE CORPORATION CO., LTD.

69 Moo 3 Kingkeaw Rd., Rachatewa District, Bangplee, Samutprakarn 10540 Thailand

Email:localsale@uni-aire.com | Email.export@uni-aire.com

Tel.+662-312-4500, www.uni-aire.com

LINE @uni-aire Facebook Uni-Aire WhatsApp.+666-2312-3069

